

AIR NOZZLES AND JETS

Superior designed Air Nozzle and Jets reduce compressed air consumption and noise levels while maintaining laminar flow for strong Blowoff

WHAT ARE THEY - REASONS TO USE

Air Nozzles are the smallest amplifiers for point applications.

Air Jets entrain large volumes of surrounding air through the Jet (similar to Air Amplifiers) and are more efficient than Air Nozzles. They cover a larger blowoff target than a Nozzle.

The larger the Nozzle or the Jet the greater the efficiency for flow amplification and significant energy savings can be achieved.

It is important to recognize that amplification Nozzles and Jets are “flow” amplifiers and not force amplifiers. However the more air consumed the greater the force produced.

The most important reason to use Air Nozzles or Jets is safety. All Nex Flow™ Air Nozzles and Jets meet OSHA standard CFR 1910.242(b) for dead end pressure. Noise levels are dramatically reduced with Air Nozzles and Jets in addition to lower energy use.

Air Nozzles are available in aluminum, 304 stainless and 316L stainless steel material. Air Jets are available in aluminum for all versions. The popular High Force Air jets are available in aluminum, brass and 316L stainless steel for high temperature and food service applications.



Nex Flow™ removes the confusion from Air Jets and Nozzles. You do NOT need hundreds of different nozzles. All air amplifying Nozzles produce air flows up to 25 times the compressed air consumed. Different Nozzles have different outlet sizes and the more air used, the greater the force produced. Noise reduction up to 10 dBA as well as reduced air consumption when compared to open Jets and Tubes.

By maintaining a reasonable choice of nozzles most valid applications can be addressed with our range.

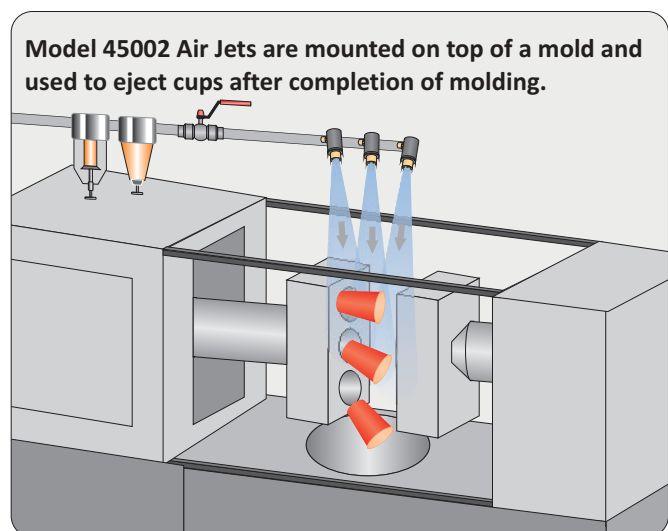
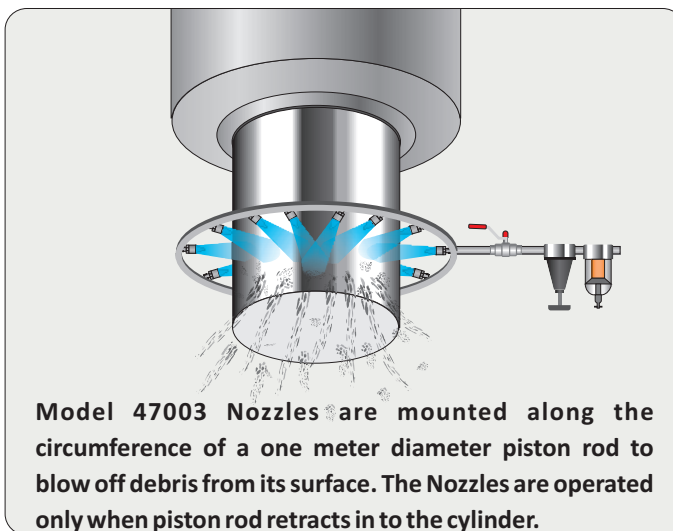

HOW IT WORKS

Air Nozzle - Models 47001, 47002, 47003, 47003S, 47003S-316L, 47004, 47004S, 47004S-316L, 47009, 47009S, 47009S-316L Compressed air enters at point (A). Surrounding air (B) is entrained over a specially designed profile surface by the action of the small amount of compressed air leaving the ring gap at point (C). This results in a concentrated high velocity, laminar flow stream of amplified air with maximized force.

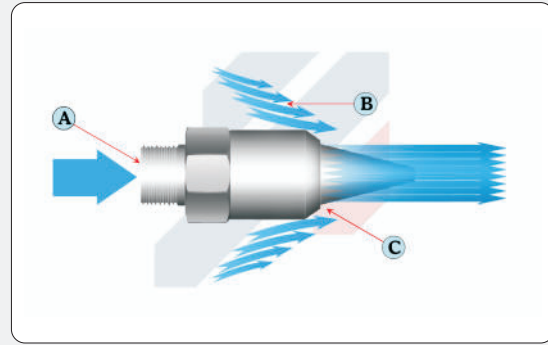

HOW IT WORKS

X-stream™ Air Nozzle - Model 47010 - Compressed air enters at point (A). Surrounding air (B) is entrained over a specially designed profile surface by the action of the small amount of compressed air leaving the small drilled holes at point (C). This results in a concentrated high velocity, laminar flow stream of amplified air with maximized force.

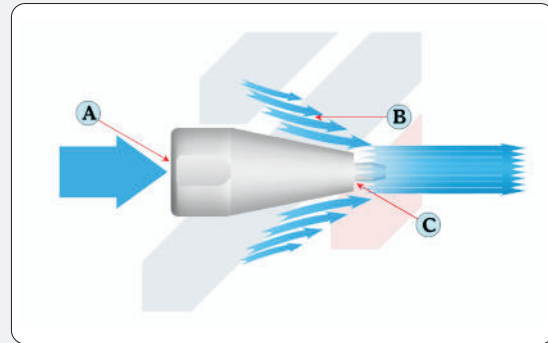

AIR NOZZLES

PART NO.	DESCRIPTION
47001	Brass Mini Nozzle with 10/32 fitting or metric equivalent
47002	Brass Mini Nozzle with copper tube - male
47003	Standard Aluminum 1/8" NPT male fitting
47003S	Standard 303/304 Stainless Steel 1/8" NPT male fitting
47003S-316L	Standard 316L Stainless Steel 1/8" NPT male fitting
47004	Extra Strong Aluminum 1/4" NPT male fitting
47004S	Standard 303/304 Stainless Steel 1/4" NPT male fitting
47004S-316L	Standard 316L Stainless Steel 1/4" NPT male fitting
47009	Adjustable Aluminum Nozzle with 1/8" male NPT fitting
47009S	Standard 303/304 Stainless Steel 1/8" NPT male fitting
47009S-316L	Standard 316L Stainless Steel 1/8" NPT male fitting
47010	X-Stream™ Anodized Aluminum Strong Force Nozzle with 1/4" female NPT fitting

STAINLESS STEEL RIGID FLEX HOSE (REFER TO PAGE M5 FOR THE RIGID FLEX HOSE)

PART NO.	DESCRIPTION
6RF (MM / MF)	6" Stainless Steel Rigid Hose which can be flexed to a shape
12RF (MM / MF)	12" Stainless Steel Rigid Hose which can be flexed to a shape
18RF (MM / MF)	18" Stainless Steel Rigid Hose which can be flexed to a shape



AIR NOZZLES:

Nex Flow™ Nozzles are designed to fit into small spaces. We have an adjustable Nozzle for some applications and then a few different Nozzles with varying force, depending on the application.



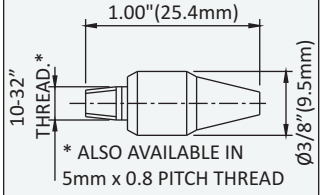

Model 47001 - Is a small brass Nozzle to fit into small spots and used by many machine builders for blowoff applications.
Sound level 74 dBA at 3ft (0.91mm) at 80 psig (5.6 bar).



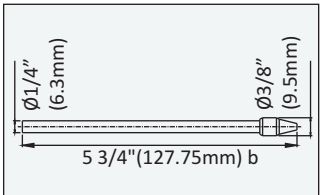

Model 47002 - Is the small Model 47001 brass Nozzle added to a copper tube. Machine builders can bend the copper tube and aim the nozzles to where ever it suits. The copper tube is simply press fit into the customer's system.
Sound level 74 dBA at 3ft (0.91mm) at 80 psig (5.6 bar).



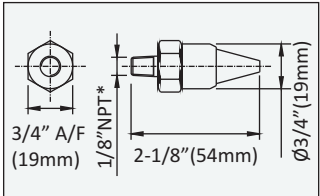

Model 47003 (anodized aluminum), 47003S (303/304 stainless steel), 47003S-316L (316L stainless steel) -
Is a common standard strength nozzle with a 1/8" male NPT connection and ideal for most blow-off applications involving liquids. It is made of aluminum (or stainless steel) and is partially anodized for longer life. The coanda profile is made for excellent noise reduction and blow-off force at a good distance
Sound level 77 dBA at 3ft (0.91mm) at 80 psig (5.6 bar).



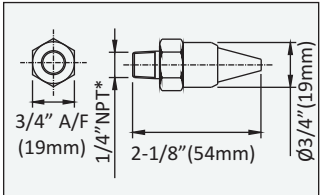

Model 47004 (anodized aluminum), 47004S (303/304 stainless steel), 47004S-316L (316L stainless steel) -
Is another common but stronger force nozzles with a 1/4" male NPT connection and ideal for most blow-off applications involving liquids and even light weight parts. It is made of aluminum (or stainless steel) and is partially anodized for longer life. Again the coanda profile is made for excellent noise reduction and blow-off force at a good distance.
Sound level 78 dBA at 3ft (0.91mm) at 80 psig (5.6 bar).



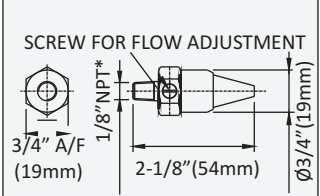

Model 47009 (anodized aluminum), 47009S (303/304 stainless steel), 47009S-316L (316L stainless steel) -
Is similar to the 47003 except it is made adjustable. The Superior design of the adjustable set screw is made to adjust the nozzles within its weakest and strongest ranges.



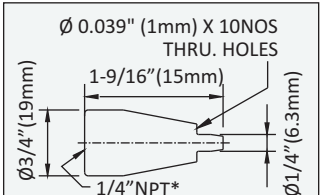

Model 47010 - Is a unique design by Nex Flow™ and is extremely powerful. It has a 1/4" female NPT fitting and is fully anodized for long life. With the 'coanda' profile you get an extremely strong force at a distance. This is an ideal Nozzle for blow guns and for blowing small parts for part ejection heavier viscosity liquids. The 47010 is a higher force Nozzle but has less distance for laminar flow than the 47004. Use the Model 47004 is greater distance required from the Nozzle.
Sound level 78 dBA at 3ft (0.91mm) at 80 psig (5.6 bar).

*BSP Threads or Adaptors can be supplied depending on country location.

Air Consumption At Various Pressure for Model 47001 and 47002 Air Nozzles

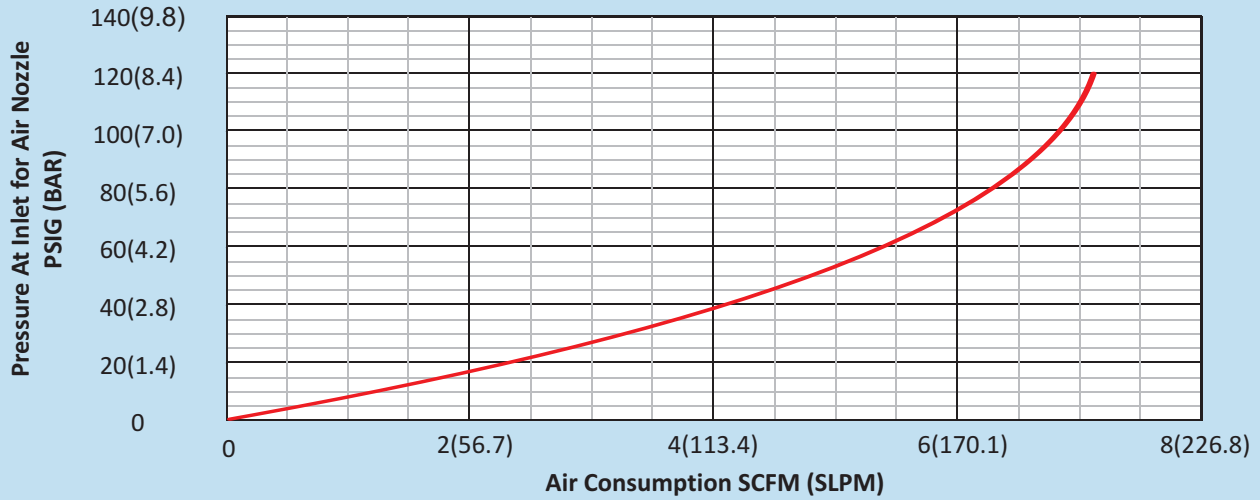

Force At Various Pressure for Model 47001 and 47002 Air Nozzles

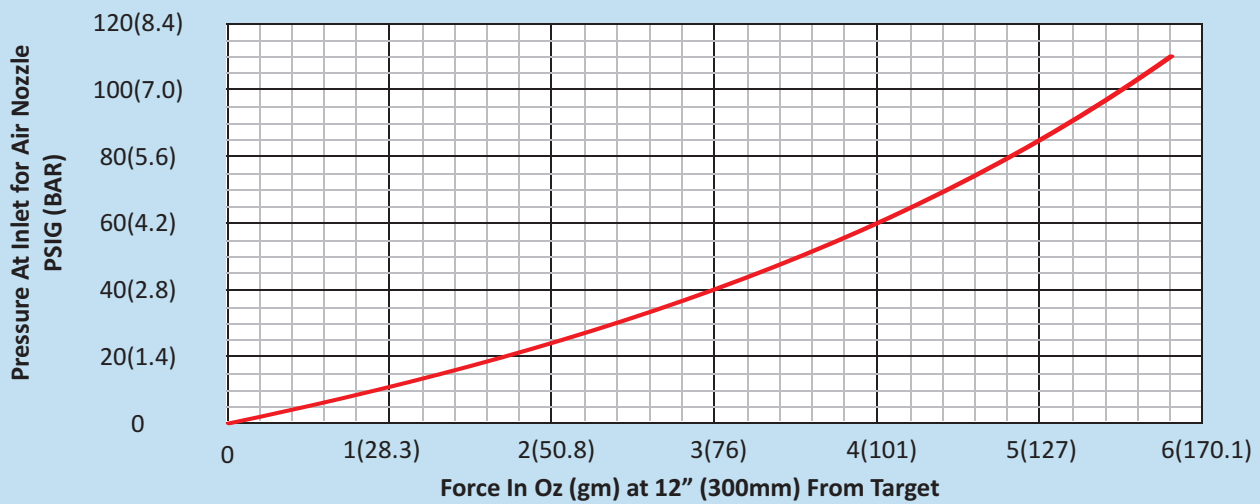

Air Consumption At Various Pressure for Model 47003, 47003S and 47003S-316L Air Nozzles.

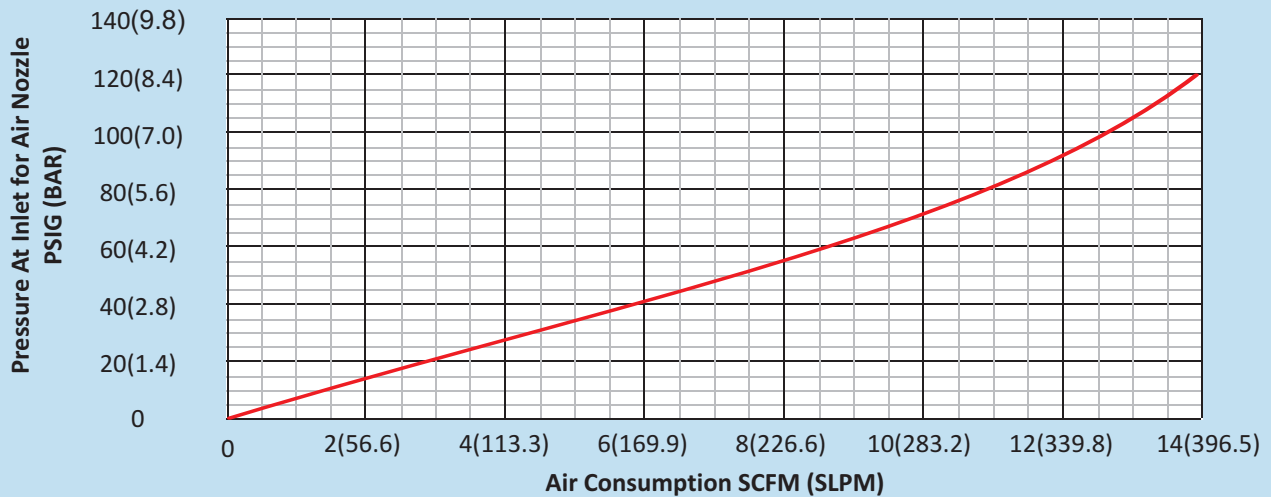

Force At Various Pressure for Model 47003, 47003S and 47003S-316L Air Nozzles.

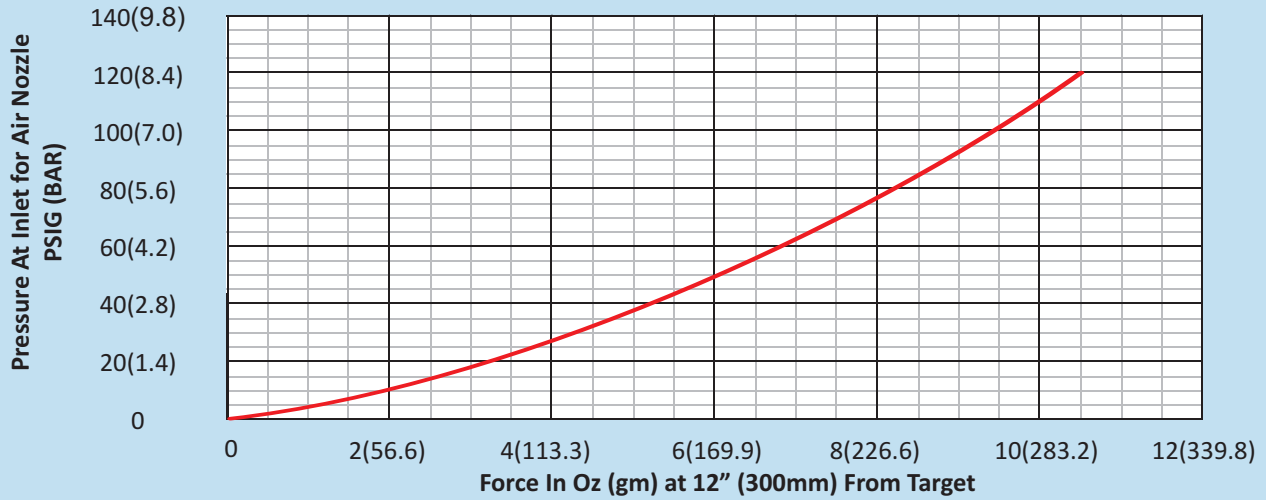

Air Consumption At Various Pressure for Model 47003, 47003S and 47003S-316L Air Nozzles.

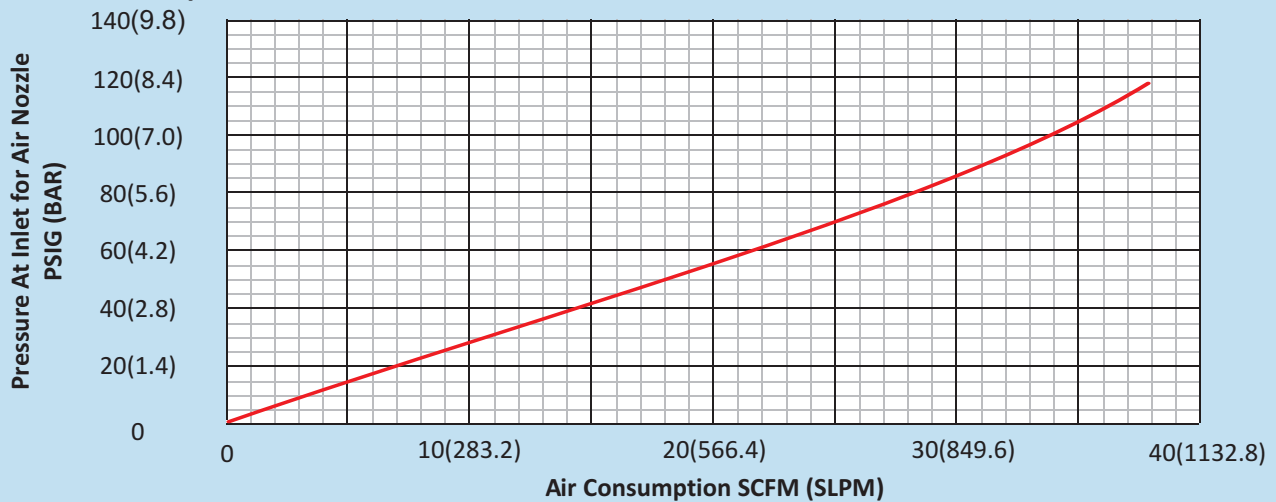

Force At Various Pressure for Model 47004, 47004S and 47004S-316L Air Nozzles.

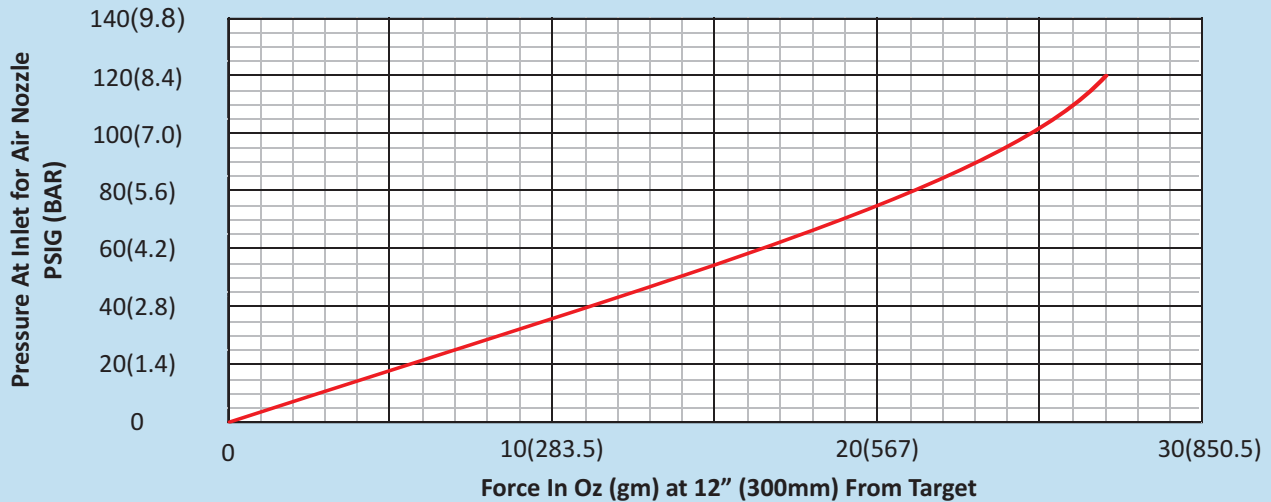

Air Consumption At Various Pressure for Model 47009, 47009S and 47009S-316L (Max Open condition)

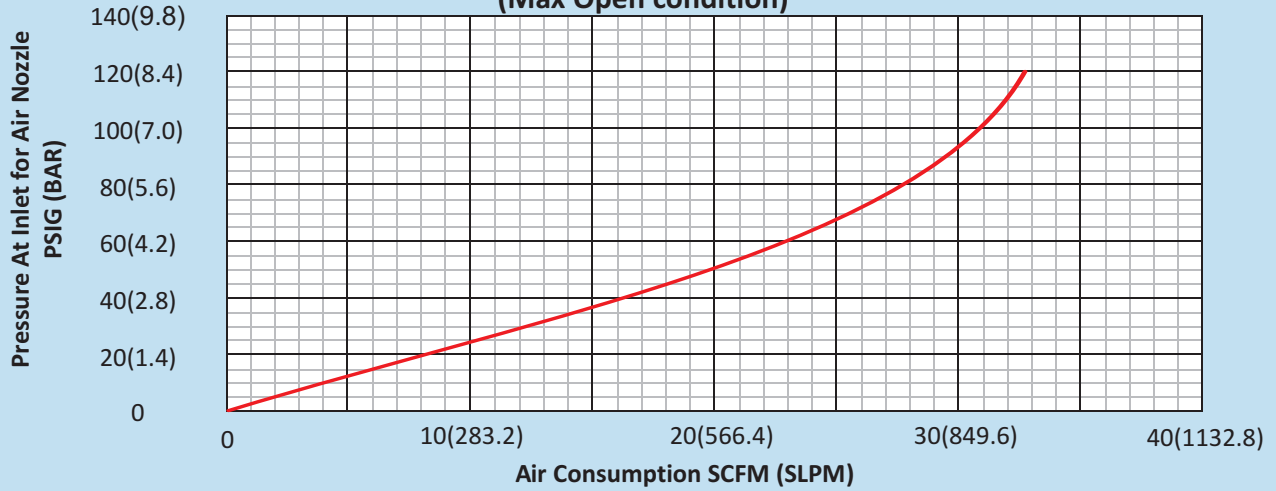

Force At Various Pressure for Model 47009, 47009S and 47009S-316L (Max Open condition)

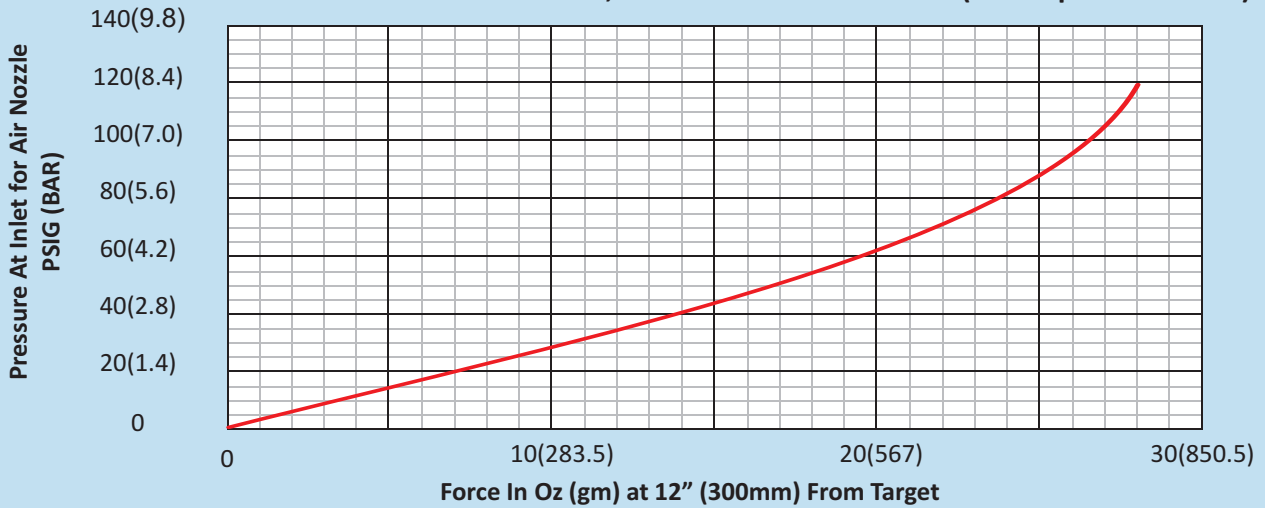

Air Consumption At Various Pressure for Model 47010 (10 Holes)

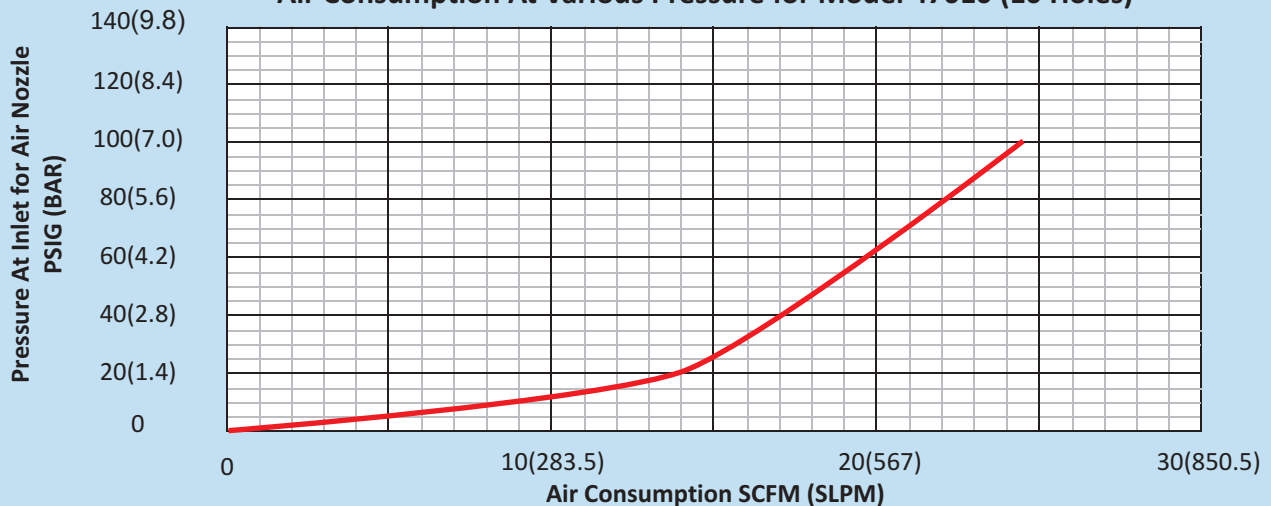

Force At Various Pressure for Model 47010 (10 Holes)

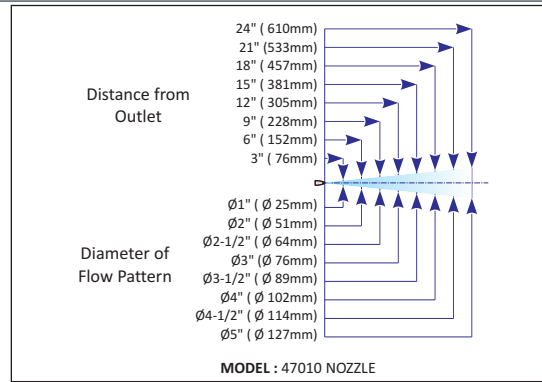
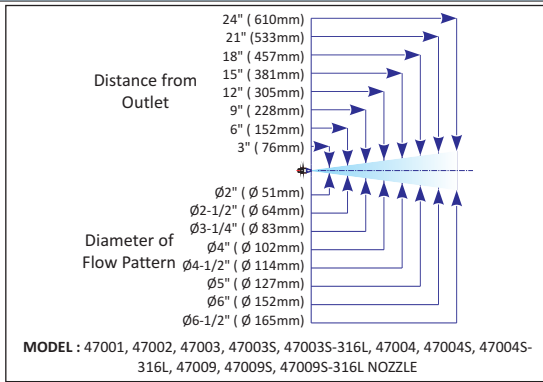
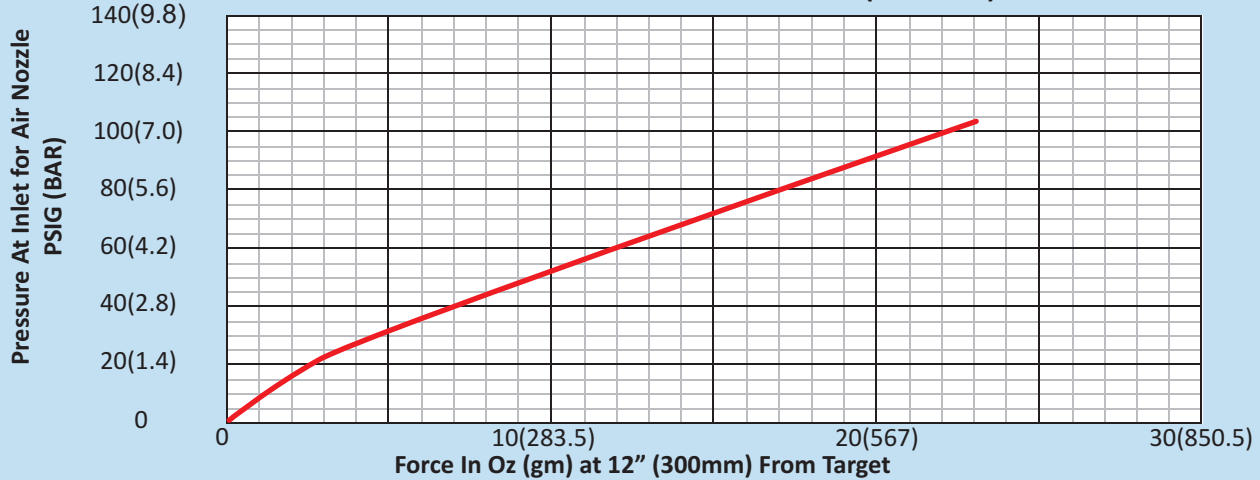

AIR NOZZLES

PART NO.	DESCRIPTION
47001	Brass Mini Nozzle with 10/32 fitting or metric equivalent
47002	Brass Mini Nozzle with copper tube - male
47003	Standard Aluminum 1/8" NPT male fitting
47003S	Standard 303/304 Stainless Steel 1/8" NPT male fitting
47003S-316L	Standard 316L Stainless Steel 1/8" NPT male fitting
47004	Extra Strong Aluminum 1/4" NPT male fitting
47004S	Standard 303/304 Stainless Steel 1/4" NPT male fitting
47004S-316L	Standard 316L Stainless Steel 1/4" NPT male fitting
47009	Adjustable Aluminum Nozzle with 1/8" male NPT fitting
47009S	Standard 303/304 Stainless Steel 1/8" NPT male fitting
47009S-316L	Standard 316L Stainless Steel 1/8" NPT male fitting
47010	X-Stream™ Anodized Aluminum Strong Force Nozzle with 1/4" female NPT fitting

STAINLESS STEEL RIGID FLEX HOSE (REFER TO PAGE E9 FOR THE RIGID FLEX HOSE)

PART NO.	DESCRIPTION
6RF (MM / MF)	6" Stainless Steel Rigid Hose which can be flexed to a shape
12RF (MM / MF)	12" Stainless Steel Rigid Hose which can be flexed to a shape
18RF (MM / MF)	18" Stainless Steel Rigid Hose which can be flexed to a shape

AIR JETS:

Air Jets are larger than Nozzles and used when a wider area needs to be hit with the amplified air. They are significantly more efficient than Nozzles although often use as much compressed air. Their best use is to replace pairs of Nozzles that are used for part ejection or for blowoff applications that require greater force than that provided by Air Knives or Air Movers. Nozzles are for point use while air jets can fan out somewhat for better continuous blowoff when a row of them are made. Nex Flow™ Jets are all made adjustable with a lock ring to assure the security of any gap setting. They have a female 1/8" NPT and made lightweight with anodized aluminum.

6 models are available: From left to right is Model 45001 High Flow Air Jet, Model 45002 High Force Air Jet and Model 45003 Mini Air Jet all in anodized aluminum, the Model 45002B High Force Air Jet in brass and the Model 45002S High Force Air Jet in 316L Stainless Steel and the Model 45004 High Force Fat Air Jet Amplifier in anodized aluminum.



The **Mini Air Jet Model 45003** is ideal for small spots where a Nozzle may not be adequate for wider coverage of air flow. It is most compact air jet available with high force and adjustability. Sound level is 82 dBA at 3ft (0.91mm) at 80 psig (5.6 bar).

<p>High Flow Air Jet Model 45001</p>	<p>High Force Air Jet Model 45002, Model 45002B & Model 45002S</p>	<p>Model 45001 / 45002 / 45002B / 45002S - High Flow Air Jet are physically the same size. The only difference is a larger exit opening for the amplified air flow. The high flow system is used more for cooling and light blowoff while the high force version is used mainly for heavier blowoff applications.</p> <p>The Sound level for Model 45001 is 80 dBA and for the Model 45002/ 45002B / 45002S it is 82 dBA at 3ft (0.91mm) at 80 psig (5.6 bar).</p> <p>The 45002B Brass Air Jet and the 45002S 316L Stainless Steel Air jet are marked to indicate the size of the air gap and can be easily set and locked into place.</p> <p>*BSP Thread or adaptors can be supplied depending on country location.</p>
<p>Mini Air Jet Model 45003</p>	<p>High Force Air Jet Model 45004</p>	

Air Jets perform similar to Adjustable Air Amplifiers - with the same lock ring and methodology. Nex Flow™ Air Jets are adjustable and come with a lock ring to fix the gap.

HOW IT WORKS

Model 45001, 45002, 45002B, 45002S, 45003 and 45004 Air Jets use a small amount of compressed air entering the annular chamber and exit via small ring nozzle at high speed over a "coanda" profile. This creates a vacuum entraining outside air converting the pressure to a high flow output while maintaining a high blowoff force. Energy cost and noise levels are reduced as a result.



The **LARGE FAT Air Jet Air Amplifier** is the largest flat jet/smallest air amplifier with the same design as the high performance air jets to give you the most optimal performance with an adjustable gap and lock ring to set the gap in place.

WHAT THEY ARE – REASONS TO USE

Nex Flow™ **FAT Air Jet Air Amplifier** is made of anodized aluminum and with a fine thread for a fine and accurate adjustment of the air gap to the setting desired for any particular application.

The *Nex Flow™* **FAT Air Jet Air Amplifier** is a transition size in between an air jet and the larger air amplifiers. It provides for superior air flow amplification and high force for blow off and cooling applications.

RIGID FLEX HOSE NOZZLE ACCESSORIES - TO HOLD AND AIM NOZZLES AND JETS

The unique *Nex Flow™* **RIGID FLEX** hose is an all stainless steel hose that does not break after a few bends like competitive rubber hoses with simple copper inserts. It is resistant to creep and crimping. Its all stainless construction allows it use in any difficult environment. They have 1/4" male NPT welded end connections and come in 6", 12" and 18" overall lengths.



Air Consumption At Various Pressure for Air Jet Model 45001 - .004" setting.

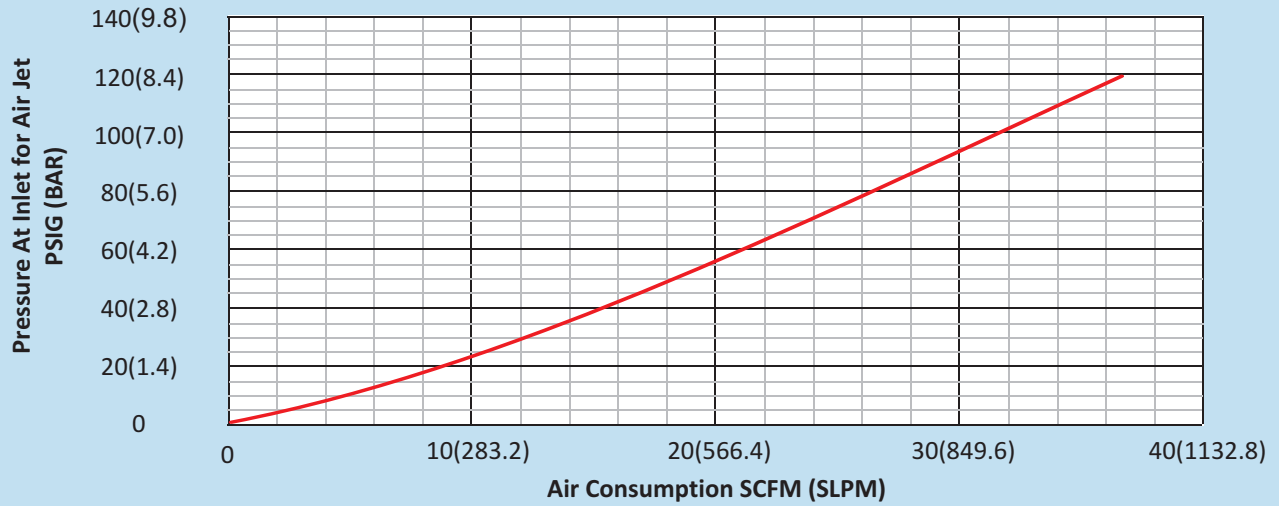

Force At Various Pressure for Air Jet Model 45001 - .004" setting.

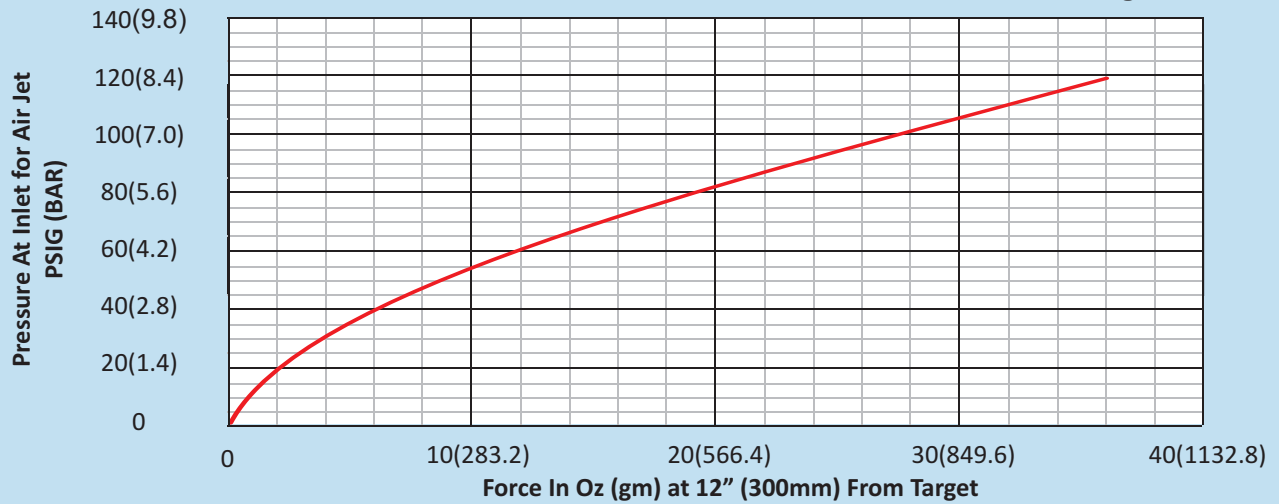

Air Consumption At Various Pressure for Air Jet Model 45002/45002B/45002S - .004" setting.

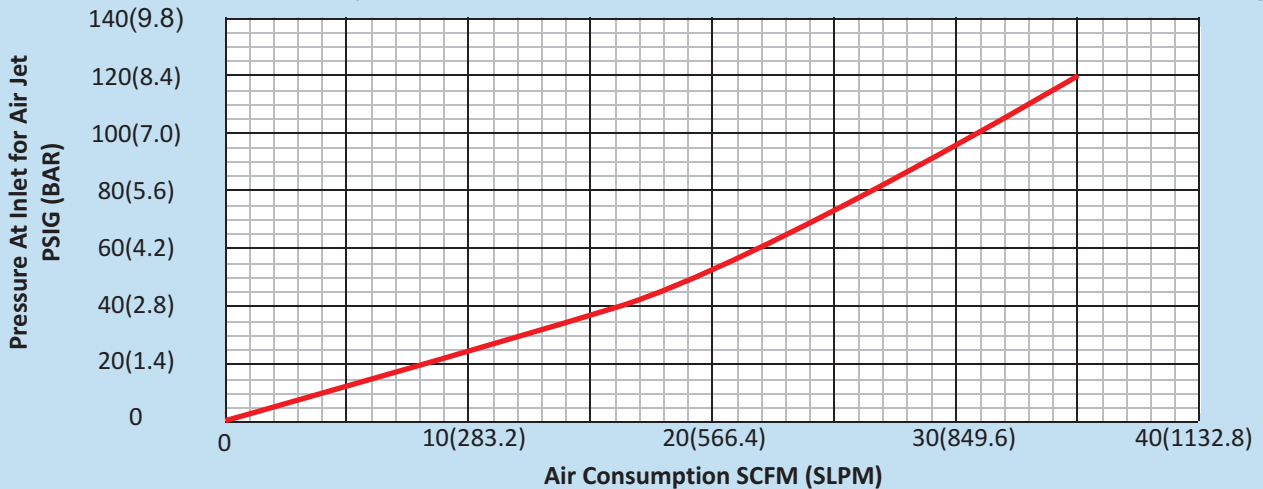

Force At Various Pressure for Air Jet Model 45002/45002B/45002S - .004" setting.

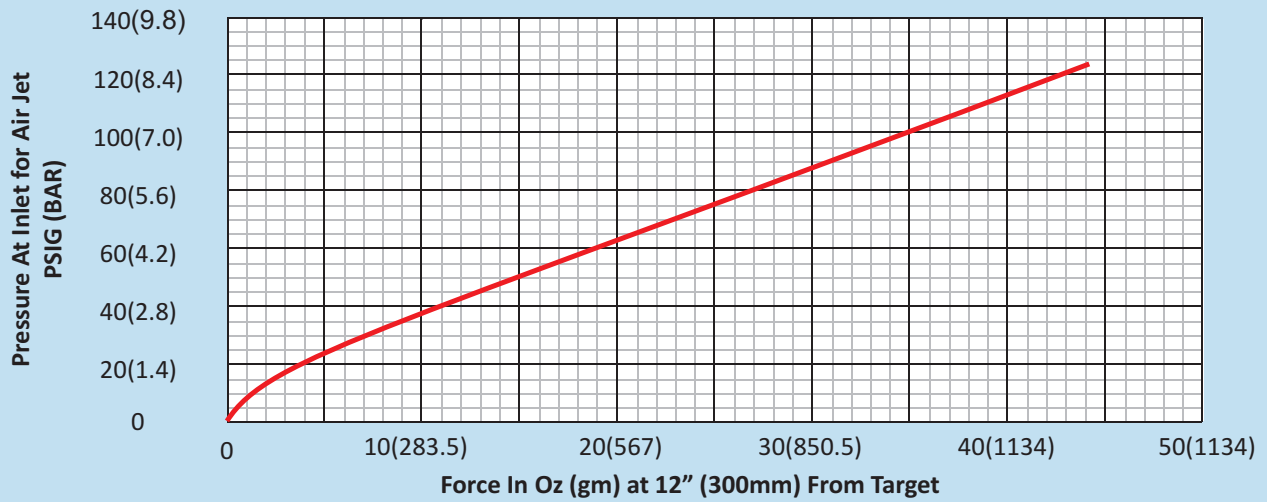

Air Consumption At Various Pressure for Air Jet Model 45003 - .004" setting.

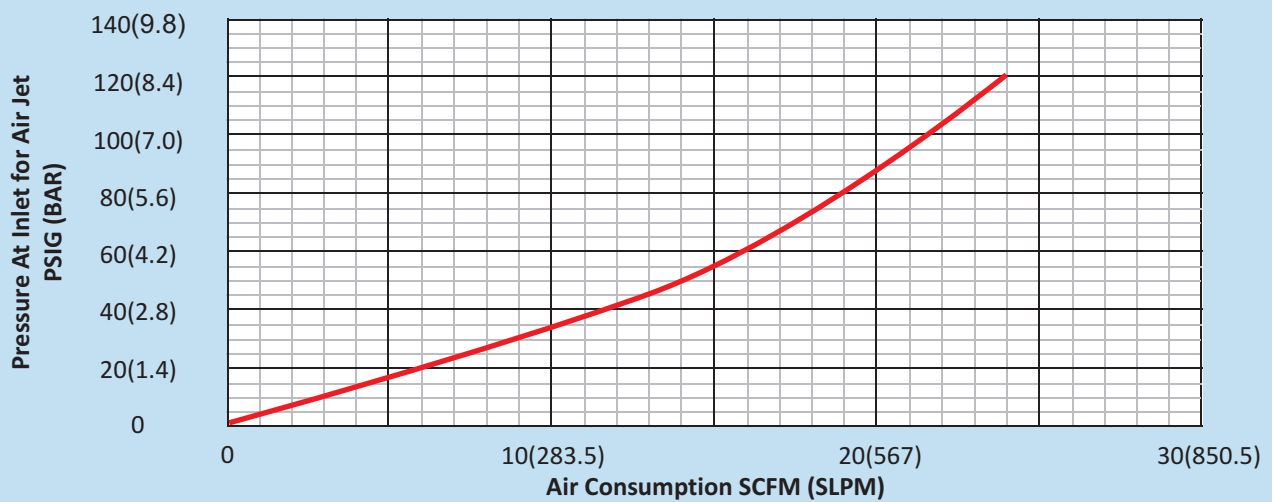

Force At Various Pressure for Air Jet Model 45003 - .004" setting.

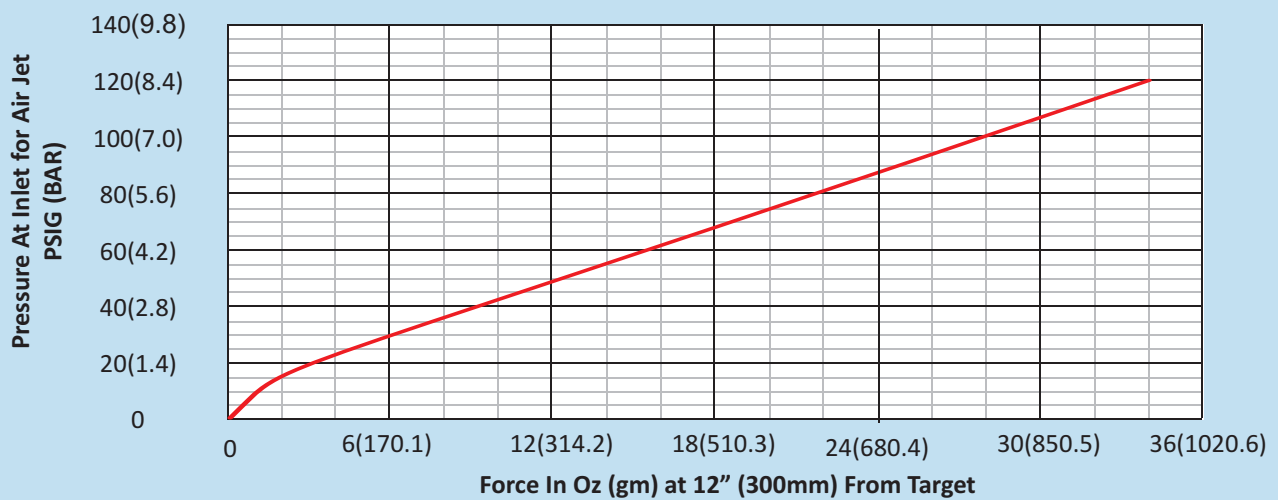

Air Consumption At Various Pressure for Air Jet Model 45004 - .002" setting.

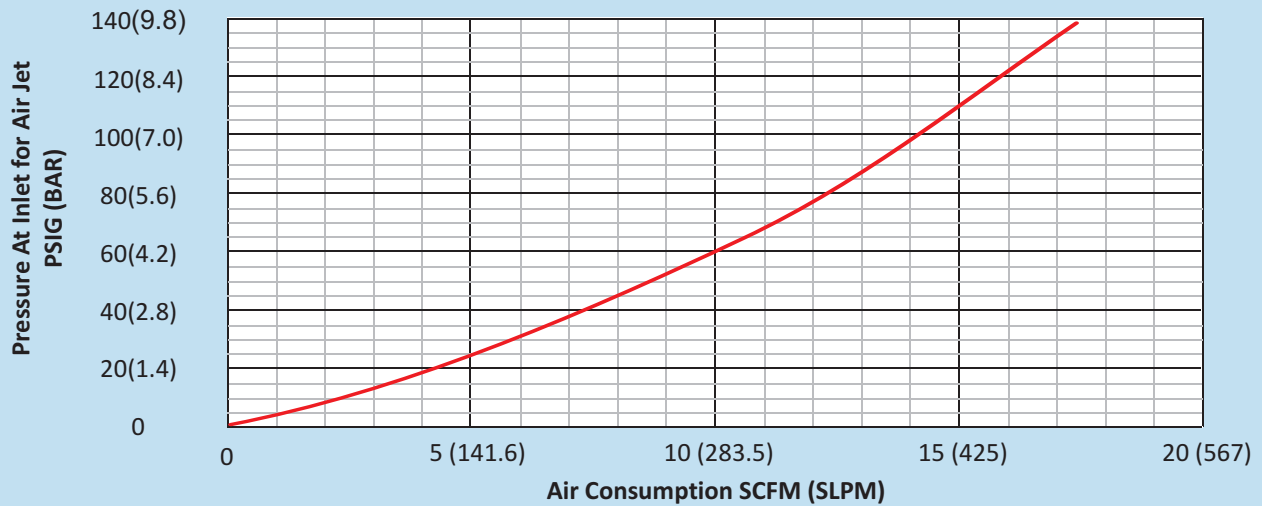

Force At Various Pressure for Air Jet Model 45004 - .004" setting.

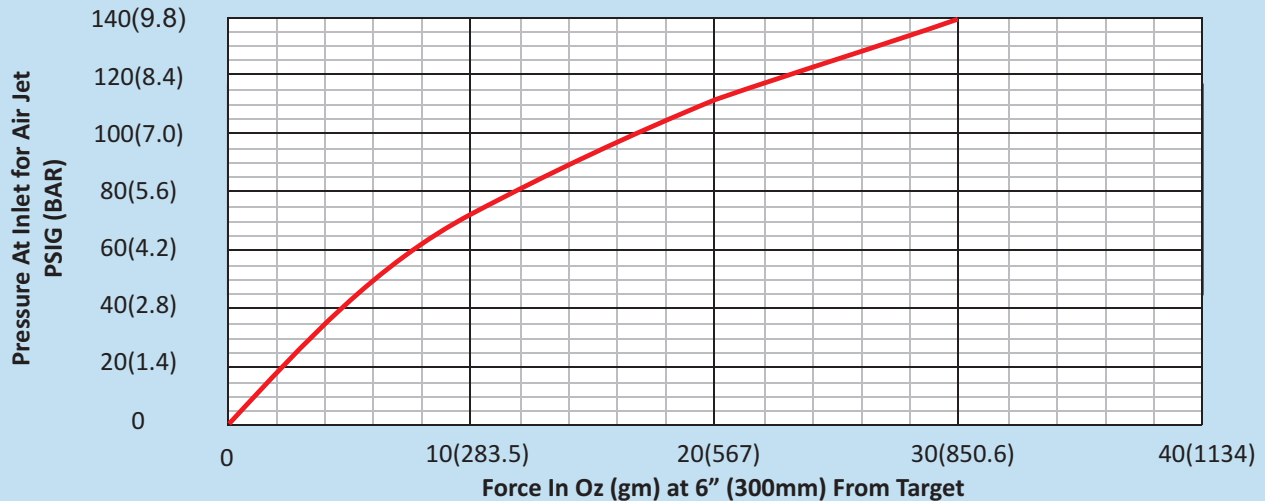

RIGID FLEX HOSE NOZZLE ACCESSORIES - TO HOLD AND AIM NOZZLES AND JETS

The unique Nex Flow™ RIGID FLEX hose is an all stainless steel hose that does not break after a few bends like competitive rubber hoses with simple copper inserts. It is resistant to creep and crimping. Its all stainless construction allows it use in any difficult environment. They have 1/4" male NPT welded end connections and come in 6", 12" and 18" overall lengths.



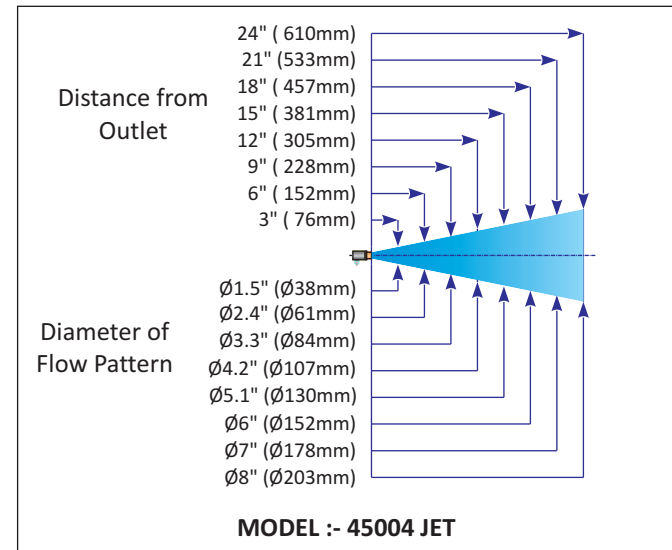
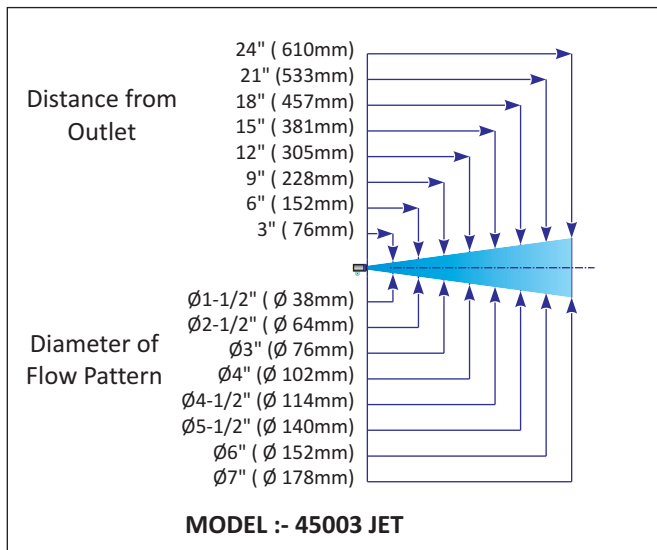
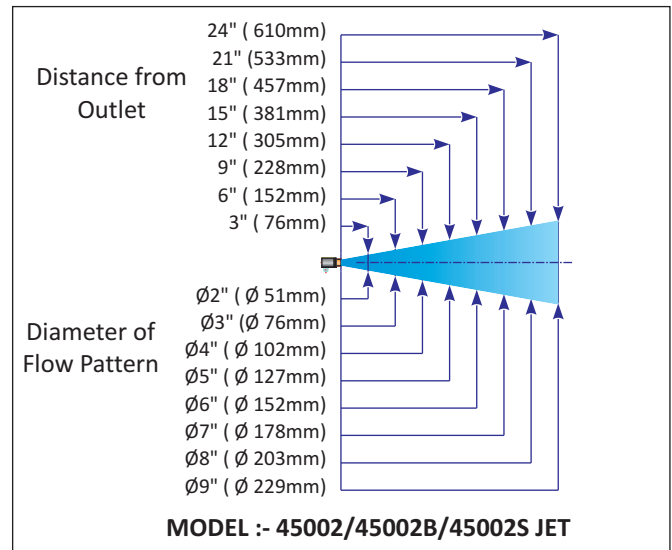
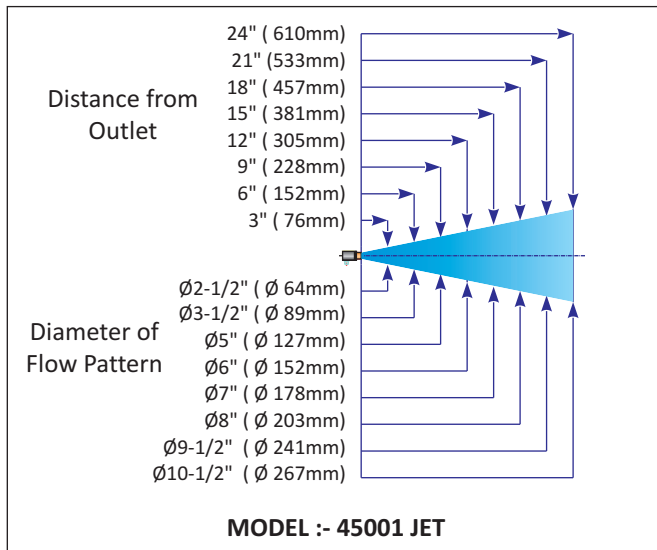

AIR JETS

PART NO.	DESCRIPTION
45001	High Flow Air Jet (aluminum, unmarked)
45002	High Force Air Jet (aluminum, unmarked)
45002B	High Force Air Jet (Brass, marked to indicate gap setting)
45002S	High Force Air Jet (316L stainless, marked to indicate gap setting)
45003	Mini - High Force Air jet
45004	Fat Air Jet Air Amplifier (aluminum, unmarked)

STAINLESS STEEL RIGID FLEX HOSE

PART NO.	DESCRIPTION
6RF (MM / MF)	6" Stainless Steel Rigid Hose which can be flexed to a shape
12RF (MM / MF)	12" Stainless Steel Rigid Hose which can be flexed to a shape
18RF (MM / MF)	18" Stainless Steel Rigid Hose which can be flexed to a shape

AIR EDGER™ FLAT JET NOZZLE

Superior designed Flat Jet Nozzle reduces compressed air consumption and noise levels

– with the use of different shims can vary the force from weak to strong depending on the application

WHAT ARE THEY - REASONS TO USE

Model **47011** (cast zinc) **Air Edger™ Flat Jet** and Model **47011S-316L** (316L stainless steel) is an extremely efficient flat jet air nozzle designed to provide a powerful stream of high velocity laminar flow and high force for blow off and cooling where air knives may not be enough

When bench tested against several other flat jets, even those with special designed holes or shims, the **Air Edger™ Flat Jet** outperformed them all despite whatever claims others may make. Air consumption and noise levels are minimized with its special design and configuration.



The **Nex Flow™ Air Edger™ Flat Jet** is available with various size “gaps” all set by a flat shim. Three standard shim sizes are available - .004” (.10 mm), .008” (.2mm) and .020” (.51 mm). One, two or more shims can be “stacked” for a larger gap and greater force.

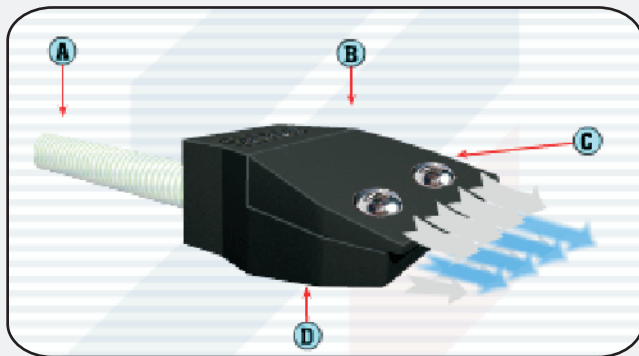

HOW IT WORKS

Compressed air enters the flat jet at the rear port at (A). Air is entrained at point (B) and (D) by the compressed air stream that leaves the flat jet from a small gap at the end. The entrained air follows the profile that directs the airflow in a perfect straight line to create a uniform sheet of air along the 2” length of the Air Edger™ Flat Jet Nozzle. The amplified air stream maximizes velocity and force to produce a well-defined sharp edge laminar flow with minimal wind shear for reduced energy use in blow off and cooling. Two screws at (C) allow you to vary the gap with a variety of sizes of shims (.004”, .008” or .020”). One or two shims may be used.



Air Edger™ Flat Jet with .008” gap setting blows water from under the caps on a bottling line moving at high speed



Air Edger™ Flat Jet with .020” gap setting provides a powerful force to blow off dirt and debris in an extrusion line

PERFORMANCE

AIR CONSUMPTION AND FORCE

MODEL Cast Aluminum	MODEL 316L Stainless	SCFM (SLPM) at 80 PSIG Measured at entrance to jet	FORCE in Ounces (grams) at 12" from target
Model 47011-4	Model 47011S-316L-4	20.5 (581)	12 (340)
Model 47011-8	Model 47011S-316L-8	31.3(887)	21 (595)
Model 47011-12	Model 47011S-316L-12	38.5 (1091)	27 (765)
Model 47011-16	Model 47011S-316L-16	41.0 (1161)	30 (850)
Model 47011-20	Model 47011S-316L-20	44.5 (1261)	33 (936)
Model 47011-24	Model 47011S-316L-24	47.0 (1331)	36(1020)
Model 47011-28	Model 47011S-316L-28	51.0 (1445)	39 (1106)

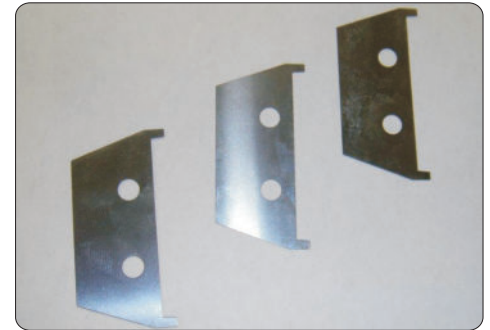

The Air Edger™ Flat Jet Nozzle air gap is set by one or more shims. There are three basic shim sizes - .004" (.1 mm), .008" (.2 mm) and .020" (.5 mm). Shims may be stacked for larger gaps and for sizes in between the shim standard sizes offered. Shims available in both 304 stainless steel & 316L stainless (for the stainless Air Edger™). The greater the gap the more powerful the force.

DIMENSIONS

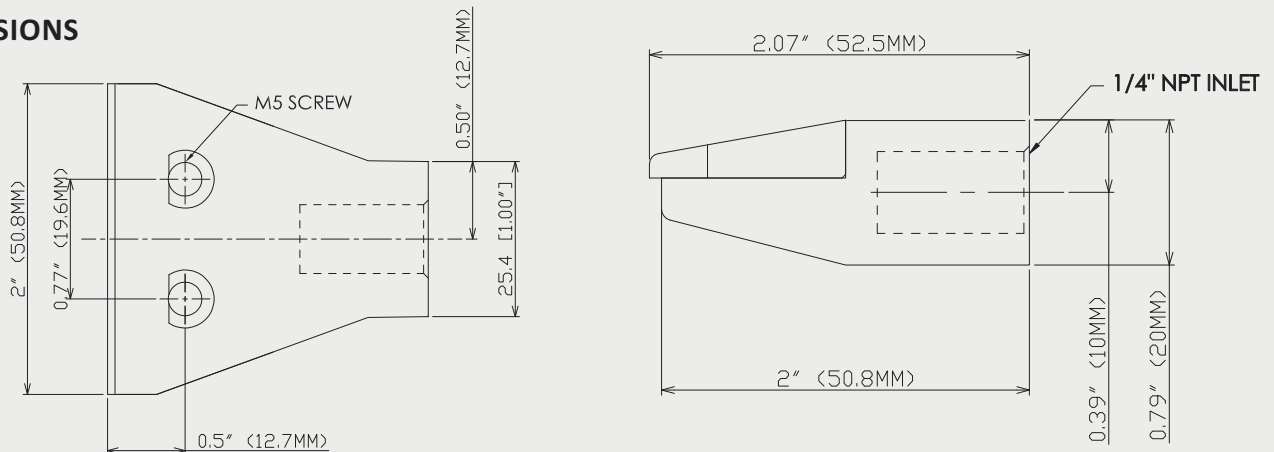

COMPARED TO COMPETITION

It is not always clear how tests and measurements are made by competitors and therefore validating claims can be difficult since such values depend on how tests are done. Therefore we measured a competitive unit under the same conditions as we measured our units. The flat jet of the competitor is of a similar type except that they are using a saw tooth shim design and different internal dimensions. We obtained the following readings when measured using the same parameters as for Nex Flow units.

25.1 SCFM AIR CONSUMPTION AND 15 oz force
(Published figures were 22 SCFM and 22 oz force)

One measure of efficiency is the ratio of Force/Air Consumption. The higher the ratio the better the efficiency. The force/SCFM is a ratio of .54 based on measured figures when measured the same way as the Nex Flow units.

If we compare to that of the Nex Flow Model 47011-4 the ratio is 12/20.5 = .58 And for the Model 47011-8 the ratio is 21/31.3 = .67

In both cases the efficiency of the Nex Flow units are higher in the comparative tests done under the same conditions.

FLAT JET NOZZLES	
PART NO.	DESCRIPTION
47011-4 & 47011S-316L-4	Air Edger™ Flat Jet with .004" gap setting
47011-8 & 47011S-316L-8	Air Edger™ Flat Jet with .008" gap setting
47011-12 & 47011S-316L-12	Air Edger™ Flat Jet with .012" gap setting
47011-16 & 47011S-316L-16	Air Edger™ Flat Jet with .016" gap setting
47011-20 & 47011S-316L-20	Air Edger™ Flat Jet with .020" gap setting
47011-24 & 47011S-316L-24	Air Edger™ Flat Jet with .024" gap setting
47011-28 & 47011S-316L-28	Air Edger™ Flat Jet with .028" gap setting
47111S-4	.004" 304 stainless steel shim
47111S-8	.008" 304 stainless steel shim
47111S-20	.020" 304 stainless steel shim
47211S	304 stainless steel shim set – Two (2) .004", Two (2) .008" and One (1) .020" shim
47111S-316L-4	.004" 316L stainless steel shim
47111S-316L-8	.008" 316L stainless steel shim
47111S-316L-20	.020" 316L stainless steel shim
47211S-316L	316L stainless steel shim set – Two (2) .004", Two (2) .008" and One (1) .020" shim

NOT SURE OF THE SIZE YOU NEED?

If you are not sure of which level of power you need, we recommend a Model 47211S Shim Set (for the cast zinc model) or a Model 47211S-316L Shim Set (for the 316L stainless steel model). The shim set consists of 2 - .004" shims, 2 - .008" shims and 1 - .020" shim and any two shims (or more) can be stacked to set the gap best suited to your application.

RIGID FLEX HOSE NOZZLE ACCESSORIES - TO HOLD AND AIM NOZZLES AND JETS



The unique Nex Flow™ RIGID FLEX hose is an all stainless steel hose that does not break after a few bends like competitive rubber hoses with simple copper inserts. It is resistant to creep and crimping. Its all stainless construction allows it use in any difficult environment. They have ¼" male NPT welded end connections and come in 6", 12" and 18" overall lengths.



STAINLESS STEEL RIGID FLEX HOSE (REFER TO PAGE M5 FOR THE RIGID FLEX HOSE)	
PART NO.	DESCRIPTION
6RF (MM / MF)	6" Stainless Steel Rigid Hose which can be flexed to a shape
12RF (MM / MF)	12" Stainless Steel Rigid Hose which can be flexed to a shape
18RF (MM / MF)	18" Stainless Steel Rigid Hose which can be flexed to a shape